

SAFOCO

Diaphragm Actuated Gate Valve

Model DAGV

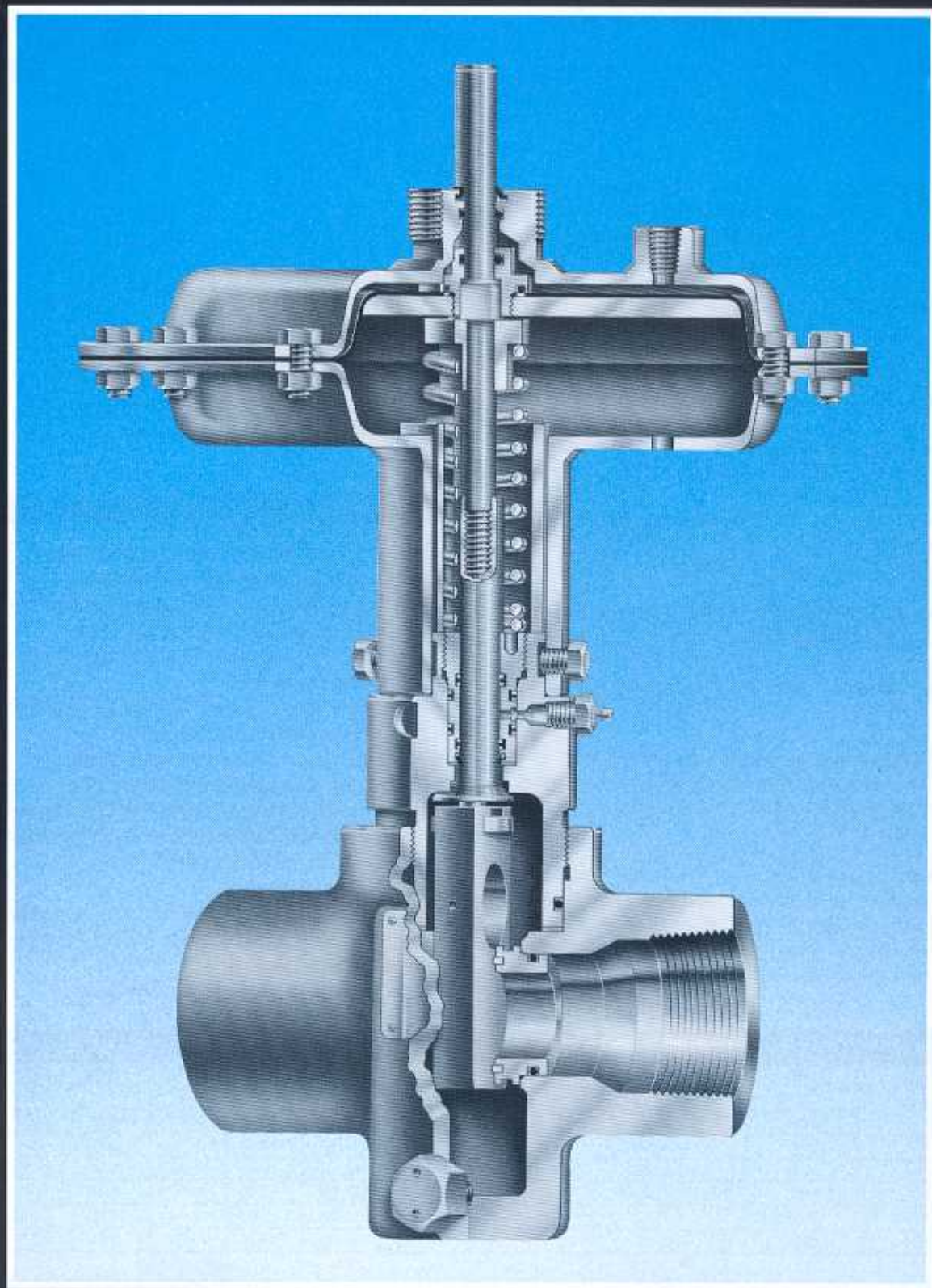

SAFOCO^{INC}

HOUSTON, TEXAS USA

SAFOCO Model DAGV Diaphragm Actuated Gate Valve

The **SAFOCO Diaphragm Actuated Gate Valve** (Model DAGV) is a versatile product suitable for many different applications throughout the industry. The model DAGV may be furnished with a reverse gate (normally closed) or a direct gate (normally open).

The **Model DAGV** is operated by the application of a pneumatic pressure supply to the diaphragm. The Model DAGV will return to its normal position (open or closed) upon loss of pneumatic pressure supply.

The **Model DAGV** has a maximum valve rated working pressure of 3000 PSI (207 bars). The maximum rated working pressure of the actuator is **75 PSI** (6 bars). Control pressure setting will depend on valve body pressure. (See pressure chart)

The **Model DAGV** is available with threaded end connection, or API 3000 RTJ, and ANSI 150, 300, 600, and 900 RF or RTJ flanged ends.

The **Model DAGV** is offered for standard service and for H₂s service applications. The standard temperature range is -20°F (-20°C) to 250°F (121°C). For special temperature applications from -50°F (-40°C) to +400°F (+205°C) contact SAFOCO.

The **Model DAGV** T-seal bonnet sealing design provides the optimum in performance and simplicity at the minimum cost. For additional or special bonnet sealing requirements contact SAFOCO.

The **Model DAGV** design features a stainless rising stem. This stem provides visual indication of valve stroke.

No torque is transmitted to diaphragm when being manually operated.

The **Model DAGV** provides an integral means for manual operation in the event of pneumatic pressure supply failure. A mechanical override can be ordered for any Model DAGV. An optional fusible lock open cap is available.

The **Model DAGV** fail safe design of the valve utilizes flowline pressure and spring force to oppose the force of the pneumatic pressure supply to the diaphragm. The DAGV incorporates a **higher** spring preload to insure sealing at low pressure. The larger spring initiates a positive fail safe operation when the pneumatic pressure supply is lost.

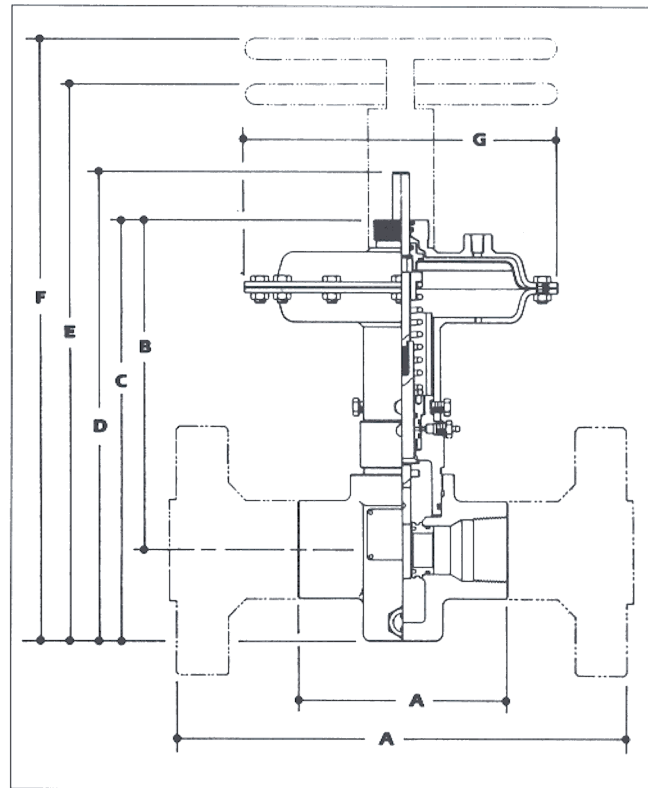

FEATURES:

- Actuator has a higher rated working pressure. System does not require low pressure regulation.
- Wiper rings for top shaft and valve bonnet stem keep sealing area clean for longer life of seals.
- Bonnet packing cartridge removed as a unit thereby eliminating down time
- Damage to diaphragm during manual operation is prevented by rotation of top shaft.
- Top shaft acts as indicator of valve stroke
- Easy spring loading with adjustable bolt
- Positive backseating assured by high energy spring.
- Manual override, fusible lock open cap are standard accessories for all Model DAGV.
- Metal to metal fire seals
- No special tools required for assembly or disassembly
- Valve can be repaired without removal from flowline
- Fail safe operation
- Free floating gate for bi-directional flow

SIZE	CONNECTION	MAX W. P	CONTROL PRESSURE	BORE SIZE	A	B	C	D	E	F	G
2"	S. E.	3,000	60 PSI	1.25	7.50	11.70	15.00	16.90	19.80	21.70	11.30
2"	150 R. F.	285	15 PSI	1.25	7.00	11.70	15.00	16.90	19.80	21.70	11.30
2"	300 R. F.	740	20 PSI	1.25	8.50	11.70	15.00	16.90	19.80	21.70	11.30
2"	600 R. T. J.	1480	30 PSI	1.25	11.62	11.70	15.00	16.90	19.80	21.70	11.30
2"	600 R. F.	1480	30 PSI	1.25	11.50	11.70	15.00	16.90	19.80	21.70	11.30
2"	900 R. F.	2160	45 PSI	1.25	14.62	11.70	15.00	16.90	19.80	21.70	11.30
2"	900 R. T. J.	2160	45 PSI	1.25	14.62	11.70	15.00	16.90	19.80	21.70	11.30
2"	3000 R.T.J.	3000	60 PSI	1.25	14.62	11.70	15.00	16.90	19.80	21.70	11.30



SURFACE SAFETY SYSTEMS